

Si - PIN - Photo diode - type FD-18



CHARACTERISTICS

- ▶ Increased sensitivity
- ▶ Integrated, coordinated micro optics
- ▶ No additional lenses required
- ▶ Especially small reception and squint angles
- ▶ 1,8mm model, metal housing

APPLICATION

- ▶ For all optical sensors

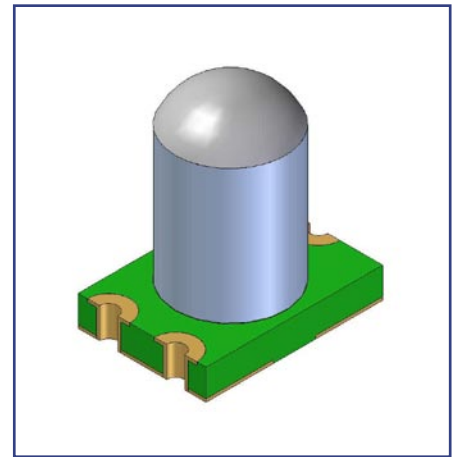

micro ● SPOT®

▶ **MAXIMUM RATINGS**

Parameter	Test conditions	typ. value	Unit
Operating temperature range (T _{op})		-20 / + 70	°C
Reverse voltage (V _R)		> 50	V

▶ **OPTICAL, MECHANICAL AND ELECTRONIC VALUES (T=25°C)**

Parameter	Test conditions	typ. value	Unit
Chip size		0,76 x 0,76	mm x mm
Chip height		0,24	mm
Dimensions of radiant sensitive area		0,55 x 0,55	mm x mm
Spectral sensitivity	650nm 875nm 940nm	0,16 0,3 0,22	A / W
Half power angle (θ)		8	deg
Dark current	V _R = 15V	< 4 (Typ. 0,2)	nA
Rise and fall time of the photocurrent	V _R = 20 V, λ = 860nm, R = 50 Ω	10	ns
Cut-of-frequency (-3dB)	V _R = 20 V, λ = 860nm, R = 50 Ω	35	MHz
Noise equivalent power	V _R = 0 V λ = 900nm	6 x 10 ⁻¹⁵	$\frac{W}{\sqrt{Hz}}$
Capacitance	V _R = 15 V	0,6	pF



Si - PIN - Photo diode - type FD-18

▶ **GRAPHS**

DIRECTIONAL CHARACTERISTICS : $I_{rel} = f(\theta)$

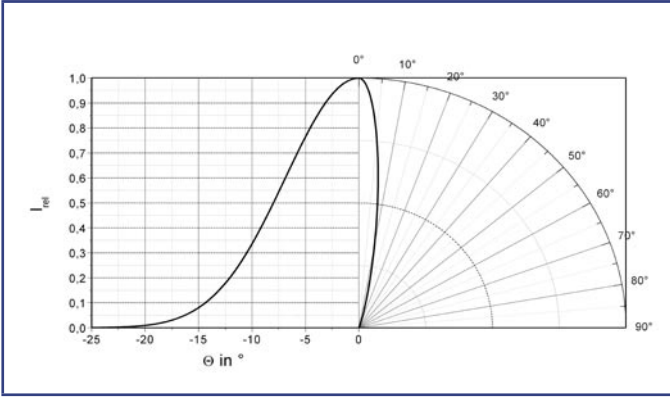

RELATIVE SPECTRAL SENSITIVITY

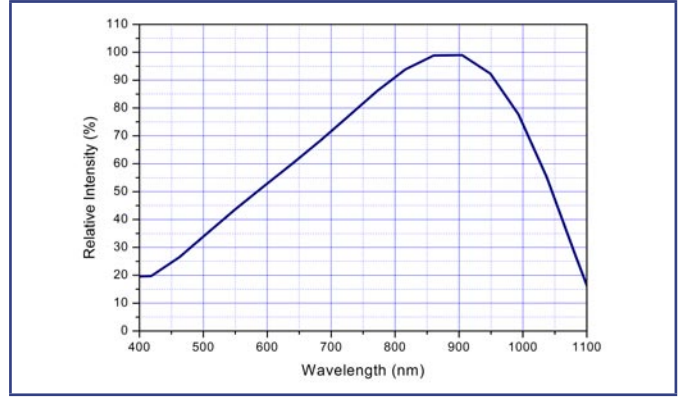

▶ **DIMENSIONS**

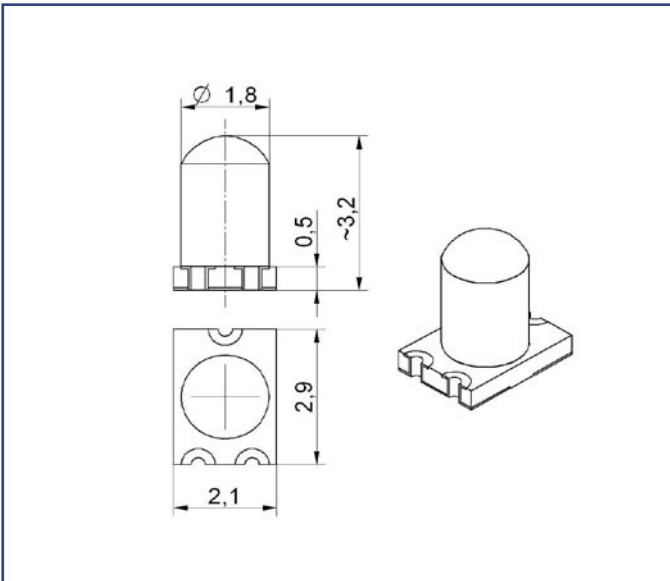

▶ **CONNECTOR PIN-ASSIGNMENT**

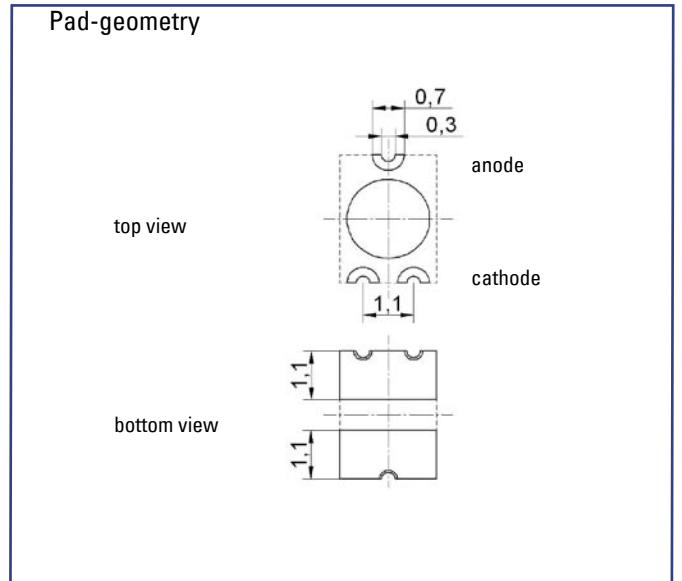

PART DESIGNATION

OE-FD-18-VA1-SL20-9-0109