

**V10-BP / V10-FP / V10-GP**  
**V10-BN / V10-FN / V10-GN**  
 (-00 / -01 / -02 / -03)

Max. frequency response **V10B:** 500Hz  
**V10F:** 3kHz  
**V10G:** 500Hz  
 pulsed  
 Functional principle LED green (PWR)  
 Power supply indicator LED yellow (OUT)  
 Function indicator LED green (PWR) blinking  
 Alarm indicator LED green (PWR) blinking  
 Alarm output 200mA, 50ms pulse length  
 Operating voltage 10 ... 30VDC (max.)  
 Output current 200mA

Current consumption **V10B:** 45mA / 180mA  
 (Ø / peak)  
**V10F:** 45mA / 90mA  
**V10G:** 45mA/180mA

Weight 65g  
 Casing material ABS  
 Operating temperature -10°C bis +55°C  
 Protection class IP65

info@stmsensors.de

www.stmsensors.de

**Wiring**

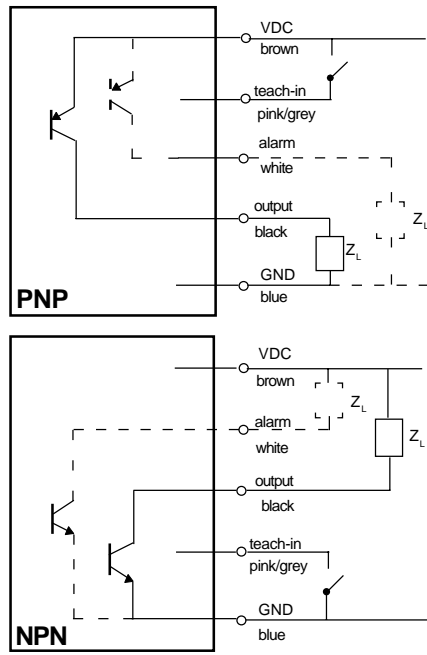

**Connection**

**Sensor**

Standard: -0  
 M8, 3pole

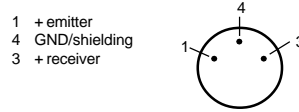

**In-/Output**

Standard -00:  
 PVC-cable, 5pole, 2m

brown + VDC  
 white alarm output  
 blue - GND  
 black signal output  
 pink remote teach

option-01:  
 M12, 5pole

1 (brown) + VDC  
 2 (white) alarm output  
 3 (blue) - GND  
 4 (black) signal output  
 5 (grey) remote teach

option-02:  
 M8, 4pole

1 (brown) + VDC  
 2 (white) alarm output  
 3 (blue) - GND  
 4 (black) signal output

option-03:  
 M8, 4pole

1 (brown) + VDC  
 2 (white) remote teach  
 3 (blue) - GND  
 4 (black) signal output

**Attention!**

Connect amplifier to 10-30 VDC only!

Do not mount amplifier cable parallel to a power line!

If the green LED is blinking (alarm indicator) when the amplifier is in operation (RUN), it indicates an unstable signal. In this case, check whether the sensor is dirty or out of alignment.

**Caution!**

Sensor and amplifier are only intended for object detection. Do not use amplifier and sensor for personnel safety applications!

**Operation**

The different operation modes and parameters are set by a 4-position slide-switch and a JOG-switch with push-button functionality.

	inscription	function
JOG-switch	+	increment
	•	push-button (confirmation of selection)
	-	decrement
slide-switch	OUT	- light-on/dark-on select; - pulse stretching
	OPT	- operation modes
	TEA	- teach-modes
	RUN	- signal strength display; - selected parameters: (⊕ = tHi, ⊖ = tLo) - external TEACH

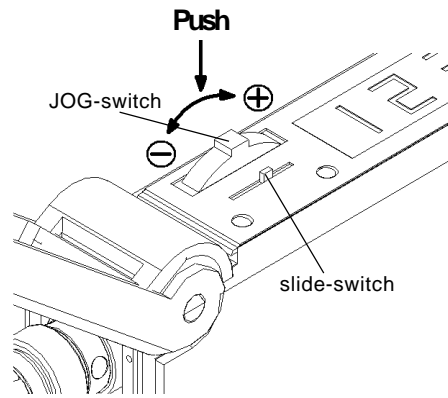

**Mount**

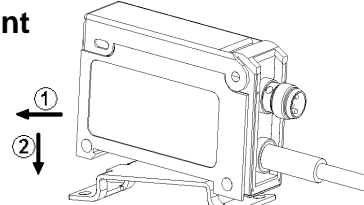

Put device onto DIN rail clip as shown. Then, connect sensor cable.

**Dismount**

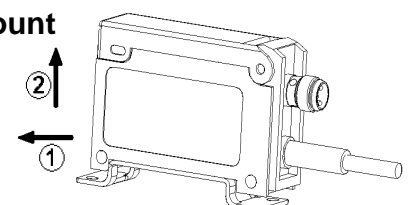

First unplug sensor cable connector. Then take amplifier off the DIN rail clip as shown.

**V10 menu navigation**

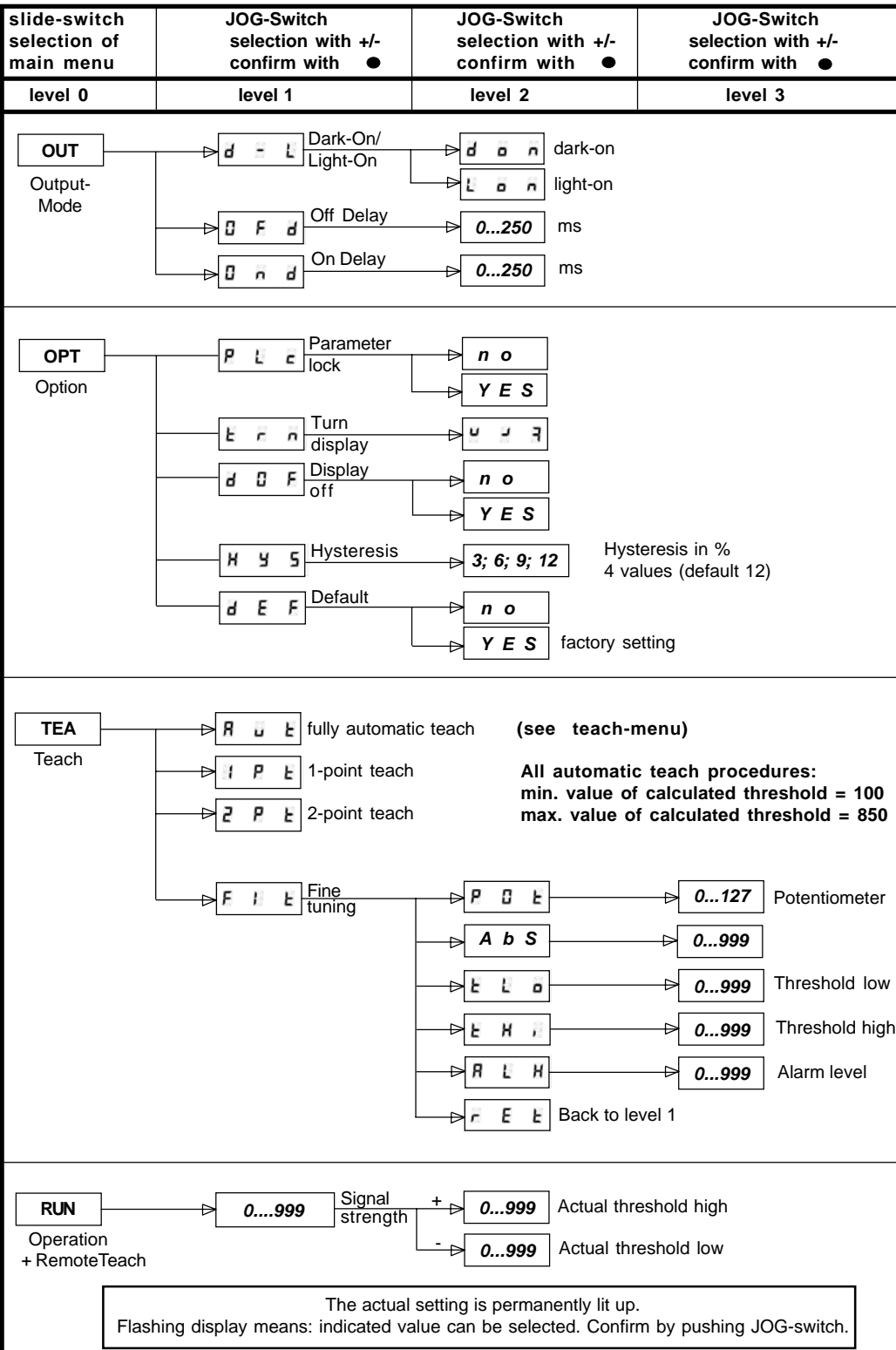

**teach menu and teach instruction**

	Manipulation	Action	Notice
		Pushing the JOG-switch activates the teach procedure. Display <b>rdy</b> confirms successful execution of the teach procedure. - Repeat teach procedure after every change in hysteresis setting. - Hysteresis recommendation: For distances > 50% of nominal => use values 9 or 12.	
<b>R u t</b>	• Push JOG-switch to start teach procedure. Switching threshold is adjusted by repeated inserting and removing of the object in the sensing beam. • Pushing of the JOG-switch terminates the procedure.	The nominal switching threshold is calculated as mean value of the detected high and low signal level. ALH, tHi and tLo are determined referring to it dependent on selected hysteresis.	 Especially recommended for cyclic processes.
<b>i p t</b>	The object is placed statically in the sensing beam. • Single push on the JOG-switch executes the teach procedure.	Nominal switching threshold, ALH, tHi, and tLo are adjusted automatically referring to the signal level in a (fixed) relation to each other.	
<b>z p t</b>	Positioning of object 1 (resp. distance 1) in the sensing beam => Push JOG-switch;  Positioning of object 2 (resp. distance 2) in the sensing beam => Push JOG-switch	The nominal switching threshold is calculated as mean value between Pt1 and Pt2. ALH, tHi and tLo are determined referring to it dependent on hysteresis.	 Higher signal level should be taught first.
<b>F i t</b>	Manual fine tuning of all relevant parameters: - for optimisation after automatic teach or - as fully manual adjustment without automatic teach.  (Only recommended for processes which cannot be adjusted by one of the automatic procedures or for correction of an automatic teach)	<b>POT:</b> Adjustment of signal amplification in 127 potentiometer steps.  <b>AbS:</b> The nominal switching threshold may be moved manually. tLo, tHi, ALH remain in the before automatically adjusted relation to each other.  <b>tLo:</b> threshold low <b>tHi:</b> threshold high <b>ALH:</b> alarm level <b>rEt:</b> return to level 1	

**Remote teach procedure**

The switching threshold of the amplifier can be adjusted remotely through the PLC via the teach-input (pink/grey).

(N.B.: only in RUN mode!).

Required voltages	PNP	NPN
Input voltage	Signal „1“: >9V	<3V
Input voltage	Signal „0“: <5V	>6V
Input current:	<3mA	<3mA

The remote teach procedure is actuated by two pulses from the PLC to the amplifier. The duration of the first pulse selects the teach mode (automatic or 2-point).

The duration of the second pulse defines the storage of the determined threshold value.

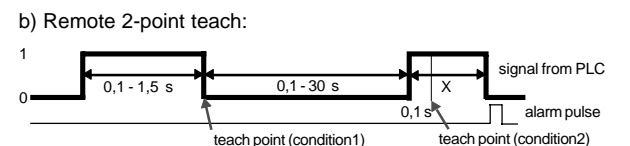
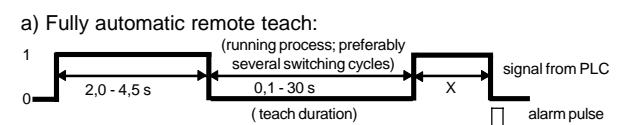

1.) X = 2,0 - 4,5s: Permanent storage (100.000 times max.); The successful teach procedure is confirmed by a signal of 100ms duration on the alarm output.

2.) X = 0,1 - 1,5s: Non permanent storage (until next power cutoff); The successful teach procedure is confirmed by a signal of 100ms duration on the alarm output.